

Heavy-duty 457mm stainless steel bowl food cutter



- Bench type food cutter with No. 12 attachment hub
- 457mm **stainless steel bowl**
- 0.75kW heavy-duty knife drive motor
- 1725 RPM knife rotation for fast efficient food cutting
- 20 RPM bowl rotation for consistent processing
- **Bowl cover safety interlock** - cover cannot be opened if machine is operating or operated if cover is open
- Double cutlery grade stainless steel knives
- Push / Pull On/Off switch
- 75mm stainless steel legs with rubber fit
- Optional accessories - mincing attachment

Technical Data

Knife rotation	1725 RPM
Bowl rotation	20 RPM
Maximum cut	25mm thick
Safety	Cover interlock
Motor size	0.75kW
Power supply	240/50/1 - 10amp (max 0.75kW)
Power cord	Plug & cord - single phase
Shipping weight	84kg

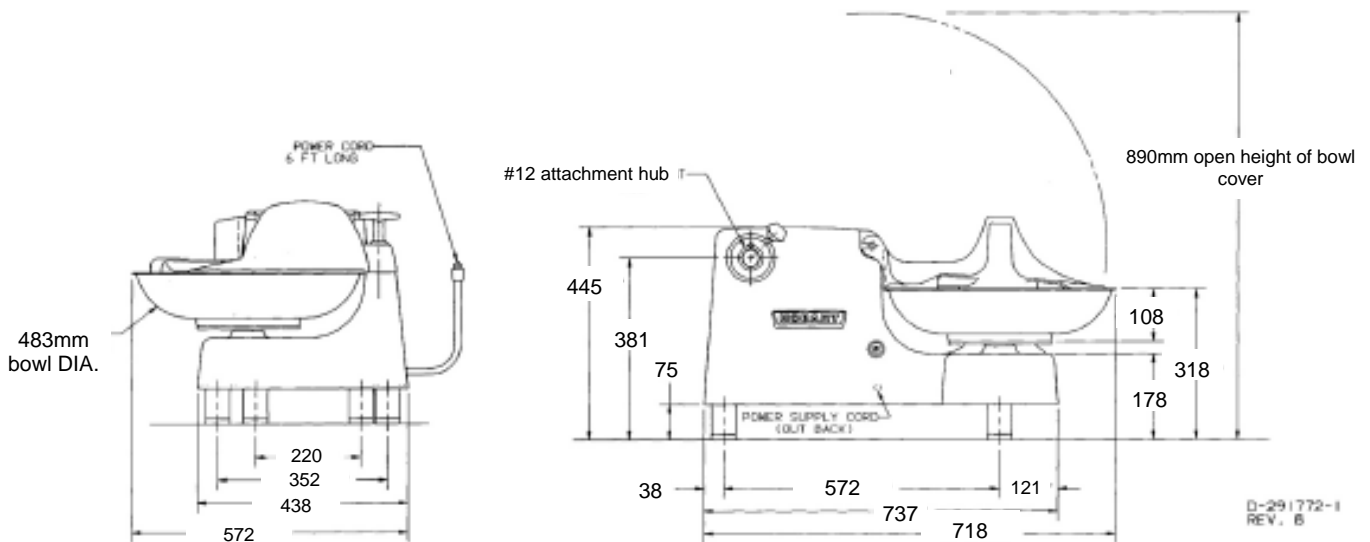

D-291772-1
REV. B

WARNING: ELECTRICAL AND GROUNDING CONNECTIONS MUST COMPLY WITH THE APPLICABLE PORTIONS OF THE NATIONAL ELECTRICAL CODE AND/OR OTHER LOCAL ELECTRICAL CODES IN FORCE.