

40 quart floor mount electronic control planetary mixer with accessories & No. 12 attachment hub

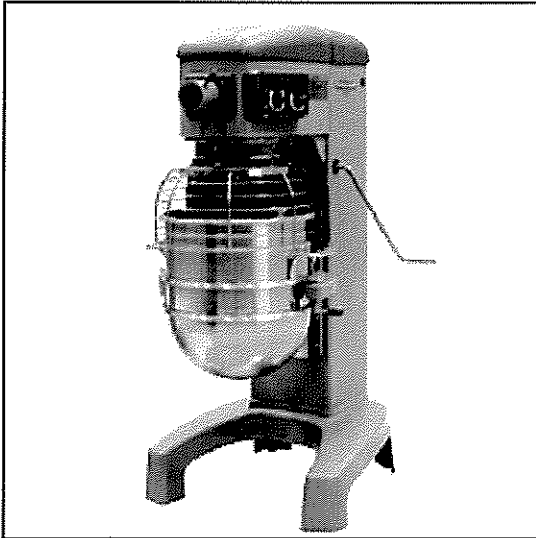

- Stainless steel **easy-on-easy-off** bowl safety guard
- Heavy-duty 1.12kW (1.5HP) motor
- **Gear transmission**
- 3 Speed, plus stir speed electronic control mixer with **SHIFT-ON-THE-FLY™** speed selection
- **Quick release agitators**
- Patented **SOFT START** agitation technology
- 20 minute **SMART TIMER™**
- Automatic time recall
- Large **easy-to-reach** controls
- Single point bowl installation
- Ergonomic **swing-out** bowl
- No. 12 attachment hub
- **Easy-clean** open base
- **Rubber foot pads provided**
- Optional accessories - Bowl scraper, splash cover and mincing attachment

Technical Data

| | |
|---------------------|--|
| Bowl size | 40 quart |
| Speeds | 3 fixed plus stir speed with SHIFT-ON-THE-FLY™ |
| Timer | 20 minute SMART TIMER™ |
| Safety guard | Stainless steel bowl guard, easy-on-easy-off |
| Standard inclusions | Stainless Steel Bowl (BOWL-HL40) B-Beater (BBEATER-HL4030) Stainless Steel D-Whip (DWHIP-HL4030) ED-Dough Hook (EDDOUGH-HL40SS) |
| Drive mechanism | Gear driven |
| Motor size | 1.12kW |
| Power supply | 415/50/3 - 10amp (max 2.7amps) |
| Power cord | Optional - refer to pricing page |
| Shipping weight | 205kg |

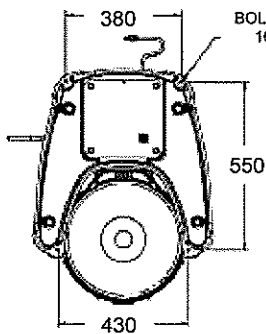
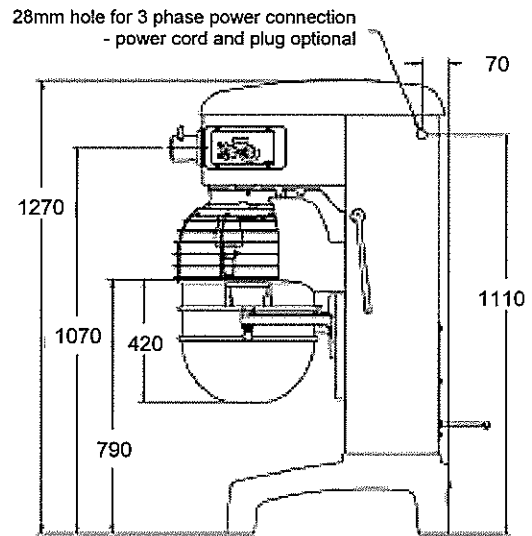
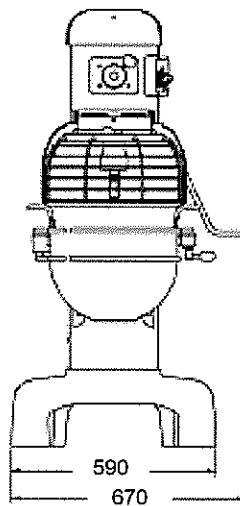

BOLT DOWN HOLES 3/8 - 16 UNC THREADS 4 PLACES

R460mm swing

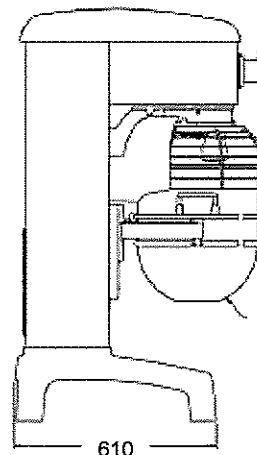
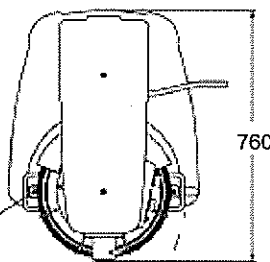

40 QUART STAINLESS STEEL BOWL - OUTSIDE DIAMETER 390mm